

## Potable Water Hose Reels

ReCoila® Gen III DW series reels are designed for the transfer of drinking water. The hose has a special inner tube that does not taint or compromise the water quality. Ideal applications are fresh water filling stations for marine pleasure craft, caravan and mobile home filling stations or simply the transfer of drinking water.

Model	Hose ID	Hose Length	Max PSI	Inlet Fitting	Outlet Fitting	Temp Range	Weight
DW1218	12mm	18m	240	1/2" BSPF	1/2" BSPM	-5/+60°C	12Kg

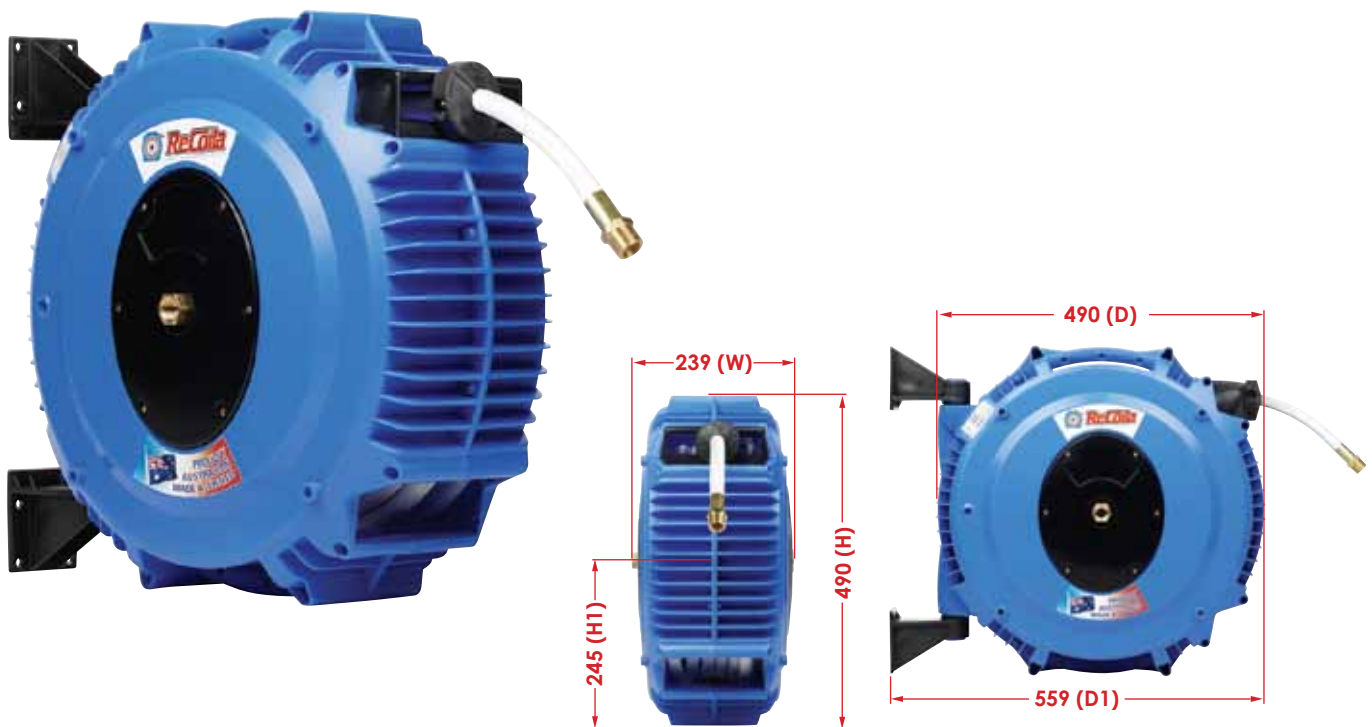

**Note:**

NPT, JIC, JIS, Metric threads are available on request. Maximum working pressure of the hose is based @ 30°C. Standard fittings swivels are MS58 brass. Optional 316 stainless steel swivels and fittings are available..



# Gen III Features & Benefits

ReCoila® Gen III composite construction reels lead the world in design, functionality, reliability and innovative features.

ReCoila® was one of the first in the world to develop and manufacture composite spring rewind reels and today we continue to be world leaders.

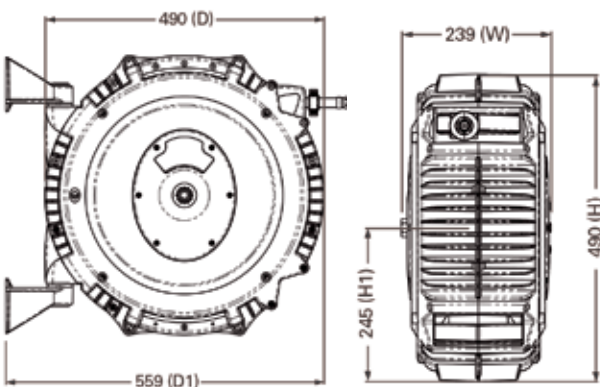

- Up to a 5 year warranty
- Highest quality 'finished edge' spring steel strip
- Full flow swivels and fluid paths
- Positive crimp hose fittings
- All position positive latching system
- Tough, impact, corrosion resistant and UV stabilized polypropylene with anti static and flame retardants
- Unique ratchet tensioning system
- Heavy Duty wall mounting swivel system
- Replaceable protective mouth guard
- Large side covers for easy access in servicing and maintenance routines
- Food grade approved materials
- Unique service locking pin port for added safety
- Two part fully adjustable bumper
- Detailed operation and service manual
- Easy mount drill hole pattern supplied

