

## Gas Welding Reels

ReCoila® Gen III OA, OP, P and A series reels are an ideal compact solution for all gas welding, cutting and shielding gas hose applications.

The unique external swivel design on the Oxygen and Fuel gas reels provides added safety and ease of O ring and seal replacement. When hoses are stored by wrapping them around the bottles or trolleys there is a greater potential of a fire risk. By installing a ReCoila® gas reel you not only create a safer working environment, but also extend the hose life and gain productivity efficiencies.

Model	Hose ID	Hose Length	Max PSI	Inlet Fitting	Outlet Fitting	Temp Range	Weight
Oxygen and Acetylene twin hose reel							
OA68	5mm	8m	300	5/8" UNFM	5/8" UNFF	-20/+80°C	12Kg
OA615	5mm	15m	300	5/8" UNFM	5/8" UNFF	-20/+80°C	12Kg
Oxygen and Propane twin hose reel							
OP68	5mm	8m	300	5/8" UNFM	5/8" UNFF	-20/+80°C	12Kg
OP615	5mm	15m	300	5/8" UNFM	5/8" UNFF	-20/+80°C	12Kg
Propane hose reels							
P620	5mm	20m	300	5/8" UNFM	5/8" UNFF	-20/+80°C	12Kg
P1015	10mm	15m	300	5/8" UNFM	5/8" UNFF	-20/+80°C	12Kg
Argon hose reel							
A620	5mm	20m	300	5/8" UNFM	5/8" UNFF	-20/+80°C	12Kg

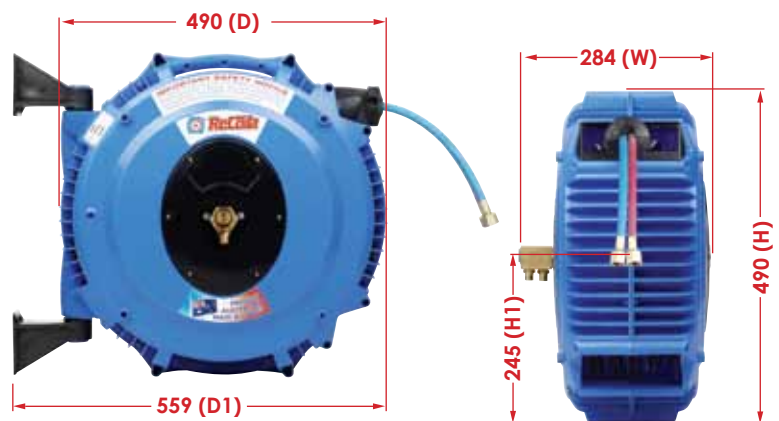

**Note:**

BSP, JIS, and other thread sizes are available. Hose design specifications are available to meet international standards such as EN599. All fuel and Oxygen gas swivels are leak tested @ 1.4psi low pressure test and 140psi high pressure test. Hose options single and twin 5mm, 6mm, 8mm 10mm.



## Gen III Features & Benefits

ReCoila® Gen III composite construction reels lead the world in design, functionality, reliability and innovative features.

ReCoila® was one of the first in the world to develop and manufacture composite spring rewind reels and today we continue to be world leaders.

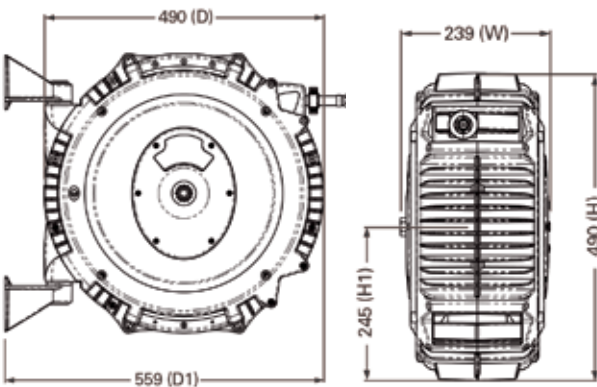

- Up to a 5 year warranty
- Highest quality 'finished edge' spring steel strip
- Full flow swivels and fluid paths
- Positive crimp hose fittings
- All position positive latching system
- Tough, impact, corrosion resistant and UV stabilized polypropylene with anti static and flame retardants
- Unique ratchet tensioning system
- Heavy Duty wall mounting swivel system
- Replaceable protective mouth guard
- Large side covers for easy access in servicing and maintenance routines
- Food grade approved materials
- Unique service locking pin port for added safety
- Two part fully adjustable bumper
- Detailed operation and service manual
- Easy mount drill hole pattern supplied

