

Rotating cleaners



Pin Fix



BSP/NPT

- Slow constant rotation
- Powerful fan jets

Turbo SSB 40

Working pressure:	2 - 5 bar (29 - 72.5 psi)
Cleaning diameter:	max. 3 m (9.8 ft)
Flow rate:	2.1 - 3.7 m ³ /h (38.3 - 61.7 l/min / 10.1 - 16.3 USgpm)
Spray angle:	360°
Operating temperature:	max. 90 °C (194 °F)
Ambient temperature/SIP:	max. 140 °C (284 °F), 30 min
Insertion opening:	BSP/NPT min. Ø 38 mm (1.5 inch) min. / Pin Fix Ø 57 mm (2.24 inch)
Materials:	stainless steel 316L (1.4404) with C-PTFE or PTFE
Preferred mounting position:	vertical down

Version	Part number
3/8" BSP female / C-PTFE ²	4660-2556-113
3/8" BSP female / PTFE	4660-2555-112
3/8" NPT female / C-PTFE ²	4660-2558-213
3/8" NPT female / PTFE	4660-2558-212

Version	Part number
Pin Fix for 1/2" OD pipe (12.7 x 1.6 mm) / C-PTFE ²	4660-2557-413
Pin Fix for 1/2" OD pipe (12.7 x 1.6 mm) / PTFE	4660-2561-412
Pin Fix for DN 15 pipe (19 x 1.5 mm) / C-PTFE ²	4660-2557-419
Pin Fix for DN 15 pipe (19 x 1.5 mm) / PTFE	4660-2561-419

² suitable for use in potentially explosive atmospheres

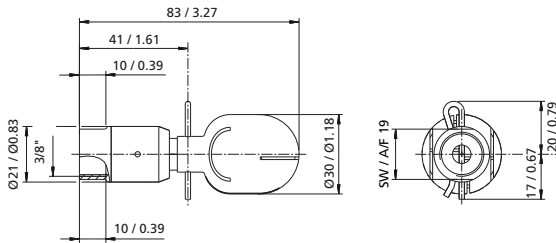

Female thread

Dimensions (mm / inch)

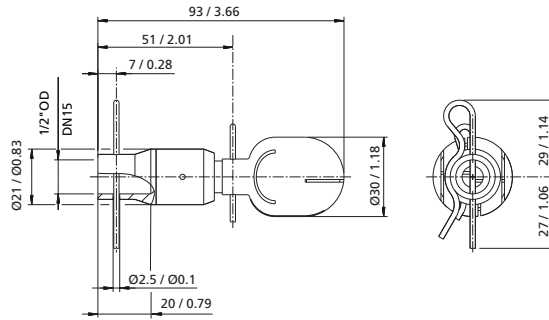

Pin Fix

