

**DOVETAIL FLAT JET TIPS**

**GY**

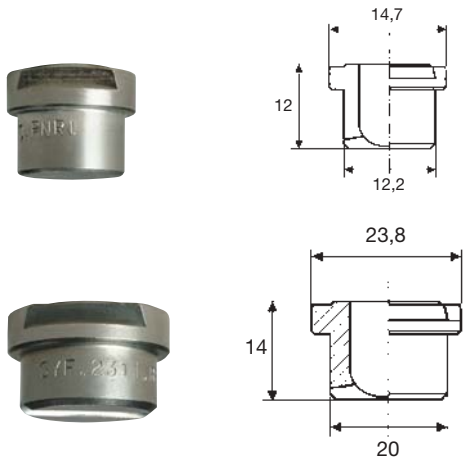

**STANDARD AND LARGE CAPACITIES**

GY flat jet nozzle tips are usually mounted onto a pipe by means of a welded nipple, and secured in place with a retaining nut. They can therefore easily be replaced and their dovetail connection assures precise assembly at all times, since the nozzle can be assembled only when the flat jet is properly oriented. The tip models shown on this page deliver the most popular capacity values, while larger capacities and sizes can be manufactured on request, and delivered complete with matching nipple and retaining nuts.

The two sizes shown are to be assembled onto 3/8" and 3/4" nipples, see nipple and retaining nut codes at the bottom of the next page.

<b>Materials</b>	<b>B1</b>	AISI 303 Stainless steel
	<b>B31</b>	AISI 316L Stainless steel
	<b>T1</b>	Brass

**How to compose the nozzle code**

The nozzle tips shown on this page can be supplied with six different spray angles, whose value is indicated by the third digit in the nozzle code. Therefore, the nozzle tip code has to be identified as in the following example.

**GYQ 1780 B31**

60°

Codes for the different spray angles are listed in the table adjacent.

**Dovetail nipples**

GY type tips are assembled onto their own series of matching dovetail nipples, to assure perfect alignment: the two tip sizes require nipples and caps as shown in the table below.

Please note that the right flat jet orientation with jets inclined so as not to disturb each other is automatically obtained welding the nipples in place with their dovetail aligned along the pipe axis.

This is easily done by running a straight rule across the dovetail profile machined on the nipple.

**Spray angle codes**

GYA	GYF	GYM	GYQ	GYU	GYW
0°	30°	45°	60°	90°	120°



Typical assembly with dovetail nipple and nut.

**Welding nipples**



ZAC 1738 xx

ZAC 2775 xx

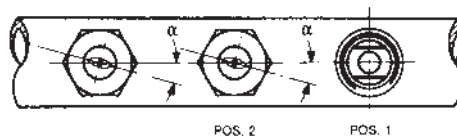

See values for jet deviation angle ( $\alpha$ ) beside capacity tables next page.

## DOVETAIL FLAT JET TIPS

**GY**

### STANDARD AND LARGE CAPACITIES

Standard capacity tips

Jet deviation angle  $\alpha = 5^\circ$

GYF	GYM	GYQ	GYU	GYW	Code	Capacity at different pressure values (lpm) (bar)								
						0.5	1.0	1.5	2.0	3.0	4.0	5.0	7.0	10
•	•	•	•	•	<b>1190</b>	0.78	1.10	1.34	1.55	1.90	2.19	2.45	2.90	3.47
•	•	•	•	•	<b>1233</b>	0.95	1.35	1.65	1.90	2.33	2.69	3.01	3.56	4.25
•	•	•	•	•	<b>1310</b>	1.27	1.79	2.19	2.53	3.10	3.58	4.00	4.74	5.66
•	•	•	•	•	<b>1385</b>	1.57	2.22	2.72	3.14	3.85	4.45	4.97	5.88	7.03
•	•	•	•	•	<b>1490</b>	2.00	2.83	3.46	4.00	4.90	5.66	6.33	7.48	8.95
•	•	•	•	•	<b>1581</b>	2.37	3.35	4.11	4.74	5.81	6.71	7.50	8.87	10.6
•	•	•	•	•	<b>1780</b>	3.18	4.50	5.52	6.37	7.80	9.01	10.1	11.9	14.2
•	•	•	•	•	<b>1980</b>	4.00	5.66	6.93	8.00	9.80	11.3	12.7	15.0	17.9
•	•	•	•	•	<b>2124</b>	5.06	5.85	8.77	10.1	12.4	14.3	16.0	18.9	22.6
•	•	•	•	•	<b>2153</b>	6.25	7.20	10.8	12.5	15.3	17.7	19.8	23.4	27.9
•	•	•	•	•	<b>2194</b>	7.96	9.20	13.8	15.9	19.5	22.5	25.2	29.8	35.6

Large capacity tips

Jet deviation angle  $\alpha = 15^\circ$

GYA	GYF	GYM	GYQ	GYU	GYW	Code	Capacity at different pressure values (lpm) (bar)								
							0.5	1.0	1.5	2.0	3.0	4.0	5.0	7.0	10
	•	•	•	•	•	<b>1781</b>	3.18	4.50	5.52	6.37	7.80	9.01	10.1	11.9	14.2
	•	•	•	•	•	<b>1981</b>	4.00	5.66	6.93	8.00	9.80	11.3	12.7	15.0	17.9
•	•	•	•	•	•	<b>2125</b>	5.06	7.16	8.77	10.1	12.4	14.3	16.0	18.9	22.6
•	•	•	•	•	•	<b>2154</b>	6.25	8.83	10.8	12.5	15.3	17.7	19.8	23.4	27.9
•	•	•	•	•	•	<b>2195</b>	7.92	11.2	13.7	15.8	19.4	22.4	25.0	29.6	35.4
•	•	•	•	•	•	<b>2246</b>	10.0	14.1	17.3	20.0	24.5	28.3	31.6	37.4	44.7
•	•	•	•	•	•	<b>2311</b>	12.7	17.9	21.9	25.3	31.0	35.8	40.0	47.4	56.6
•	•	•	•	•	•	<b>2490</b>	20.0	28.3	34.6	40.0	49.0	56.6	63.3	74.8	89.5
•	•	•	•	•	•	<b>2610</b>	24.9	35.2	43.1	49.8	61.0	70.4	78.8	93.2	111
		•	•	•	•	<b>2760</b>	31.0	43.9	53.7	62.1	76.0	87.8	98.1	116	139
		•	•			<b>3122</b>	49.8	70.4	86.3	99.6	122	141	158	186	223

Assembly fittings coding

Size	Locknut	Welding nipple
Standard size 3/8"	VAA 0040 xx	ZAC 1738 xx
Large size 3/4"	VAA 0075 xx	ZAC 2775 xx