

## Fork-Lift Recharging Reels

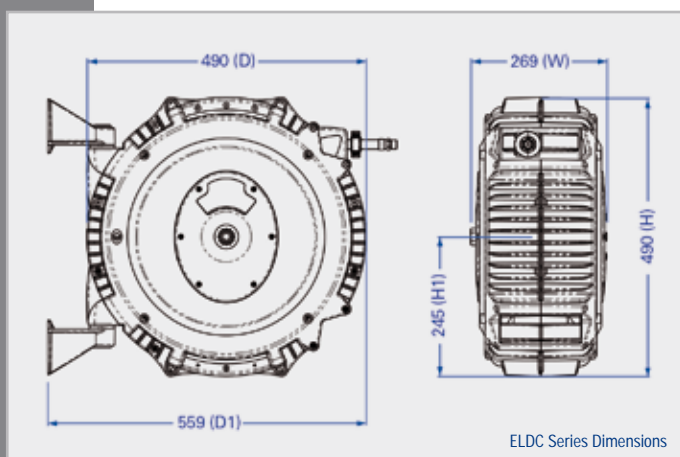

ReCoila® Gen III ELDC series reels offers an ideal solution for managing fork-lift recharging cables. Over heating cables and poor recharges are generally a result of damaged cables and connections from being left laying around. Installing a recharge reel will not only increase the life expectancy of the cables and connectors but will make the operation of recharging more efficient and offer a safer tidier work area.

Model	Cable mm <sup>2</sup>	Cable Length	No. Cores	Inlet	VDC	Amps	Outlet	Temp Range	Weight
ELDC650	16-mm <sup>2</sup>	5-m	2	Plug	600	50	Socket	-20/+80°C	12Kg
ELDC6175	16-mm <sup>2</sup>	5-m	2	Plug	600	175	Socket	-20/+80°C	12Kg
ELDC6350	16-mm <sup>2</sup>	5-m	2	Plug	600	350	Socket	-20/+80°C	12Kg



**Note:**

Slip ring rating 600 VDC @ 350 Amps. To be used with cable fully uncoiled.

