

TROLL BALL 2"

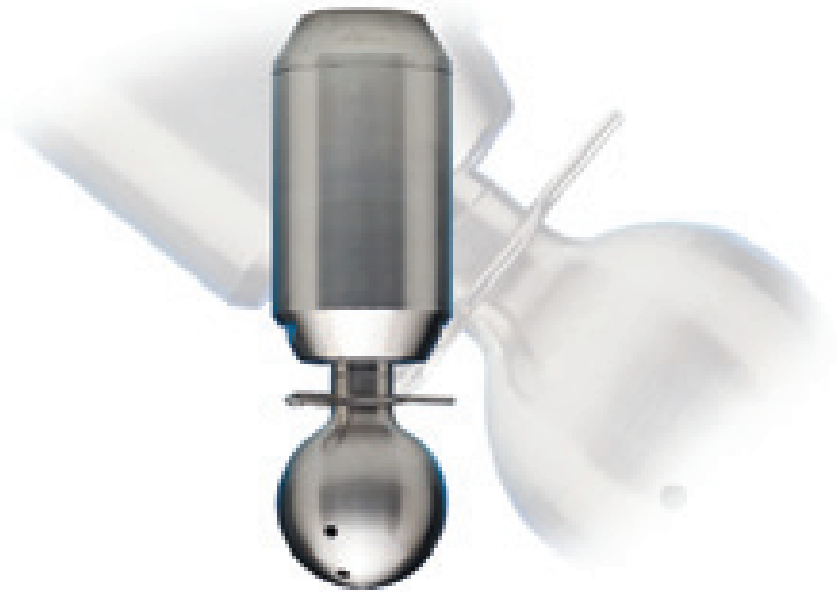

THE PERFECT SPRAYBALL REPLACEMENT

- **No Ball Bearings**
- **Minimal Moving Parts**
- **Controlled Rotation Speed**
- **Powerful Jets**
- **Reduced Contamination**
- **Lower Maintenance Costs**
- **Consistent Cleaning Pattern**
- **Reduced Cleaning Time**

Versatile & Unique

The Troll Balls simple and effective drive mechanism ensures slow constant rotation speeds. This action provides consistent cleaning when using different cleaning fluids across a wide temperature range. The minimal moving parts provide a very low maintenance, compact cleaning solution.

Applications

The Troll Ball is ideal for replacing fixed or rotating spray balls. The high energy, high impact jets provide very effective impingement up to two metres, meaning a single unit can clean vessels up to four metres in diameter. Compact in design, effective in performance, they meet all the essential FDA material requirements and are also available in ATEX exempt form. This makes the units highly suitable for the pharmaceutical, biotech, food, beverage and other hygiene conscious industries.

Operation

Wash fluid drives a simple rotating motor, which drives the rotating ball. All the wash fluid exits the unit through the small number of large holes. The specially designed pattern of holes ensures the high power jets use the minimum amount of wash fluid to deliver optimum performance.

BRECONCHERRY
SELLERSCLEAN

TROLL BALL 2"

**BRECONCHERRY
SELLERSCLEAN**

International specialists in the design and
manufacture of tank cleaning equipment

Australia & New Zealand Distributor:



TECHNICAL PROJECTS
D/L OF MATHI PRODUCTS PTY. LTD A.B.N. 83 090 115 478

4/44 Carrington Road
Castle Hill NSW 2154
Australia

Tel: +61 (0)2 9634 3370
Fax: +61 (0)2 9634 6418
Email: sales@tecpro.com.au
Web: www.tecpro.com.au



We reserve the right to change specification
without notice. Whilst we endeavour to provide
accurate up to date information, all information
is provided as a guide only.

"Breconcherry", "Trollball" are internationally
registered trade marks of Breconcherry Limited.
Copyright © Breconcherry Limited 1999

Maintenance & Inspection

The low wear design requires minimal maintenance. Any spare parts, technical assistance or repair facilities required can be obtained through the global Breconcherry distributor network. As with all mechanical devices, it is recommended that the unit be regularly inspected for correct operation.

Manhole Opening

The minimum manhole/flange opening size required for unit insertion is 70mm.

Technical Data

Material of Construction:	Stainless Steel 316/316L, PTFE, C-PTFE, PEEK, Hastelloy
Max. Operating Temperature:	120°C
Max. Ambient Temperature:	140°C
Standard Connection:	3/4" BSP/NPT Female
Nozzle Characteristics:	180° or 360° Spray Pattern
Weight:	1kg

Flow Rate Verses Pressure

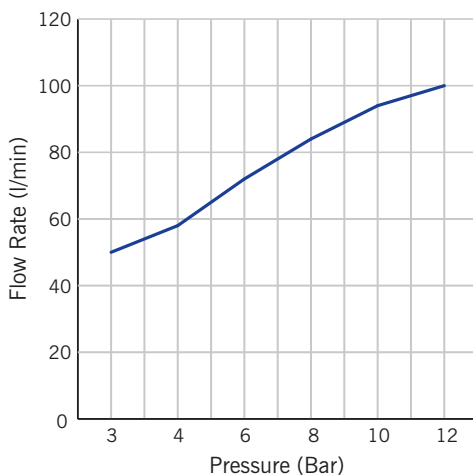

Cleaning / Wetting Radius

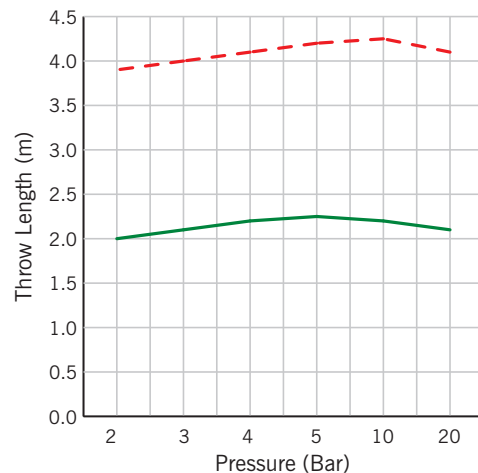

General Assembly Drawing

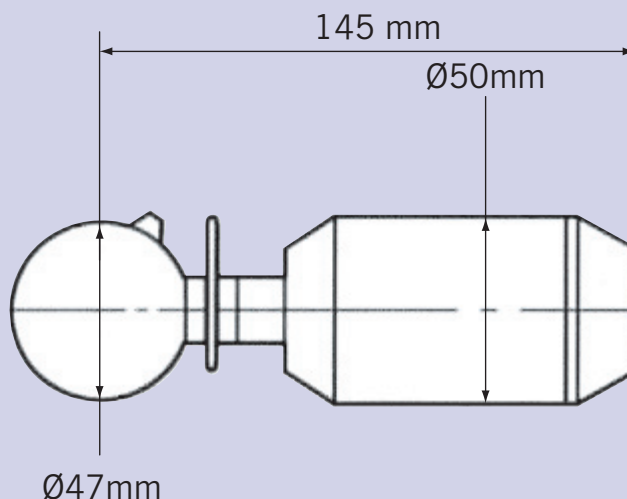

For optimal efficiency use a pre-filter or strainer to prevent particulate clogging.

**BRECONCHERRY
SELLERSCLEAN**

WWW.TECPRO.COM.AU