



THE PERFECT LOW FLOW LOW PRESSURE TANK WASHER

- **High Speed Wash**
- **Low Flow Rates**
- **Low Pressure Operation**
- **Compact Design**
- **Reduced Down Time**
- **Reduced Water, Chemical & Effluent Cost**
- **Health & Safety Friendly**
- **Ideal For Small Vessels/Pipes**

Versatile & Unique

The Breconcherry Torus is ideally suited for applications where low flow and low pressure demands are critical. The ability to operate from pressures as low as 0.5 bar with flow rates as low as 8 litres per minute enables the Torus to operate in many areas previously cleaned by manual means as well as larger main stream applications. The Torus range offers a wide choice of models which can be customised to meet individual customer requirements for flow and pressure dynamics.

Applications

Ideally suited to low flow, low pressure application such as glove box / biohazard containment areas, the rotary disc can be grasped or touched during operation and will not damage the glove. The Torus is compact enough to be mounted inside pipe work to flush pipe work through, or used to replace standard spray balls / wash heads in larger vessels. Torus is manufactured from FDA-approved materials to give complete sanitary compliance for the pharmaceutical and food industries. ATEX exempt versions are also available.

Operation

Wash fluid is directed through the slots on the rotating disc, dispensing a spray of fast moving droplets giving total coverage. Ideal for burst rinsing or prolonged washing with instant, strong impact performance. The Torus is available in 180° and 360° wash patterns.

TORUS 50 / 75

**BRECONCHERRY
SELLERSCLEAN**

International specialists in the design and
manufacture of tank cleaning equipment

Australia & New Zealand Distributor:



TECHNICAL PROJECTS
DIN. OF MATHI PRODUCTS PTY. LTD. A.B.N. 83 090 115 478

4/44 Carrington Road
Castle Hill NSW 2154
Australia

Tel: +61 (0)2 9634 3370
Fax: +61 (0)2 9634 6418
Email: sales@tecpro.com.au
Web: www.tecpro.com.au



We reserve the right to change specification
without notice. Whilst we endeavour to provide
accurate up to date information, all information
is provided as a guide only.

“Breconcherry”, “Torus” are internationally
registered trade marks of Breconcherry Limited.
Copyright © Breconcherry Limited 1999

Maintenance & Inspection

The low wear design requires minimal maintenance. No Spare parts are required. Technical assistance or repair facilities required can be obtained through the global Breconcherry distributor network. As with all mechanical devices, it is recommended that the unit be regularly inspected for correct operation.

Minimum Manhole/Flange Size

The minimum manhole/flange opening size required for unit insertion for the Torus 50 is 42mm and for the Torus 75 it is 52mm.

Technical Data

Materials of Construction:	Stainless Steel 316, PTFE, CF-PTFE PEEK, Hastelloy
Max. Operating Temperature:	95° Centigrade
Max. Ambient Temperature:	140° Centigrade
Standard Connections:	
Torus 50	3/8" BSP/NPT Female, Pin Fix, Weld Fix
Torus 75	1/2" BSP/NPT Female, Pin Fix, Weld Fix
Nozzles Characteristics:	
	4 slots
	180° or 360° Spray Pattern

Flow Rate Verses Pressure

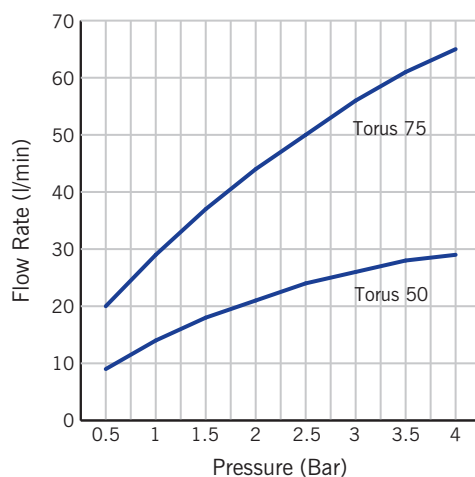

Cleaning / Wetting Radius

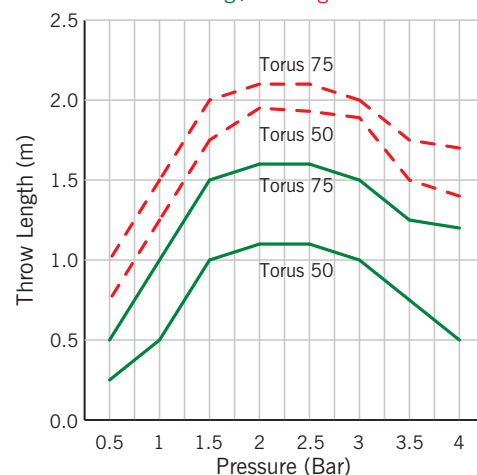

General Arrangement Drawing

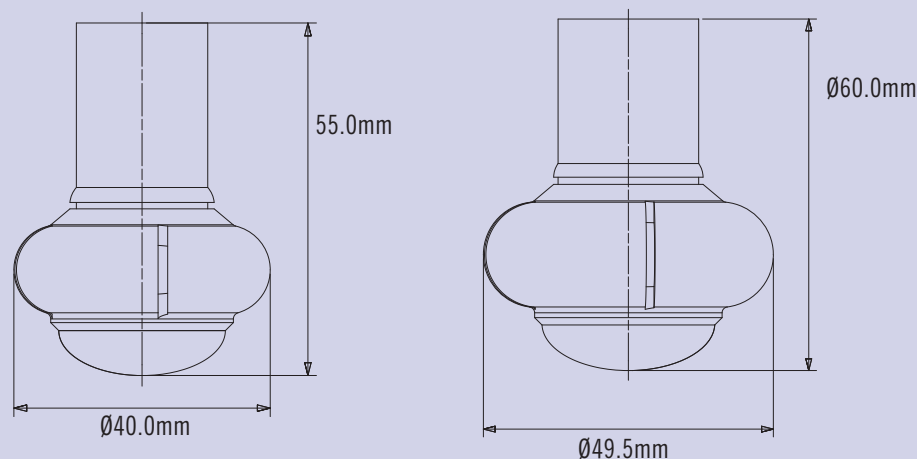

For optimal efficiency use a pre-filter or strainer to prevent particulate clogging.

**BRECONCHERRY
SELLERSCLEAN**

WWW.TECPRO.COM.AU