

TORUS 100



THE PERFECT SPRAY BALL REPLACEMENT

- **Ultra Hygienic Design**
- **One Moving Part**
- **Fast Effective Wash**
- **Powerful Jets**
- **Reduced Contamination**
- **Lower Maintenance Costs**
- **Reduced Cleaning/Down Time**
- **Reduced Cleaning Time**

Versatile & Unique

The Torus 100 has a very simple yet highly effective design. The unique design of the rotating disc of water provides instant and effective total coverage across the inside of the vessel. This action provides consistent repeatable cleaning. The single moving part provides a very low maintenance, very low cost of ownership and compact cleaning solution.

Applications

The Torus 100 is ideal for replacing fixed or rotating spray balls. The high energy, fast moving droplets provide very effective impingement up to two metres, meaning a single unit can clean vessels up to four metres in diameter. Compact in design, effective in performance, they meet all the essential FDA material requirements and are also available in ATEX exempt form. This makes the units highly suitable for the pharmaceutical, biotech, food, beverage and other hygiene conscious industries.

Operation

Wash fluid enters a drive chamber creating a disc of moving water. The wash fluid exits the unit through the small number of slots in the external disc. The specially designed pattern of slots ensures the high energy droplets use the minimum amount of wash fluid to deliver optimum performance.

BRECONCHERRY
SELLERSCLEAN

TORUS 100

BRECONCHERRY SELLERSCLEAN

International specialists in the design and
manufacture of tank cleaning equipment

Australia & New Zealand Distributor:



TECHNICAL PROJECTS

DNL OF MATHI PRODUCTS PTY. LTD A.B.N. 83 090 115 478

4/44 Carrington Road
Castle Hill NSW 2154
Australia

Tel: +61 (0)2 9634 3370
Fax: +61 (0)2 9634 6418
Email: sales@tecpro.com.au
Web: www.tecpro.com.au



We reserve the right to change specification
without notice. Whilst we endeavour to provide
accurate up to date information, all information
is provided as a guide only.

"Breconcherry", "Torus" are internationally
registered trade marks of Breconcherry Limited.
Copyright © Breconcherry Limited 1999

Maintenance & Inspection

The low wear design requires minimal maintenance. Any spare parts, technical assistance or repair facilities required can be obtained through the global Breconcherry distributor network. As with all mechanical devices, it is recommended that the unit be regularly inspected for correct operation.

Minimum Manhole/Flange Size

The minimum manhole/flange opening size required for unit insertion is 70mm.

Technical Data

Materials of Construction:	Stainless Steel 316/316L, PTFE, C-PTFE, PEEK, Hastelloy
Max. Operating Temperature:	100° Centigrade
Max. Ambient Temperature:	140° Centigrade
Standard Connections:	1" Pin Fix
Nozzles Characteristics:	180° or 360° Spray Pattern

Flow Rate Verses Pressure

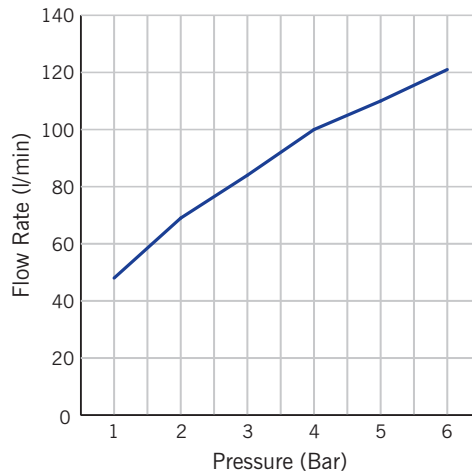

Cleaning / Wetting Radius

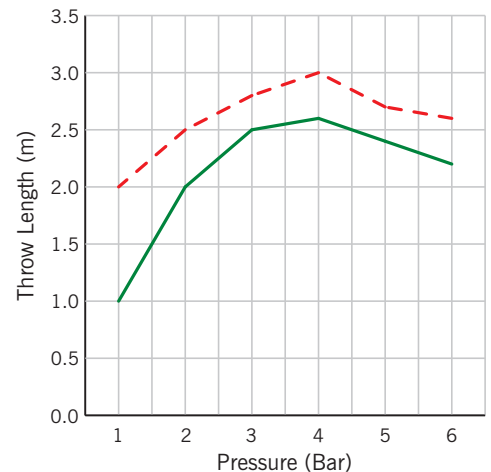

General Arrangement Drawing

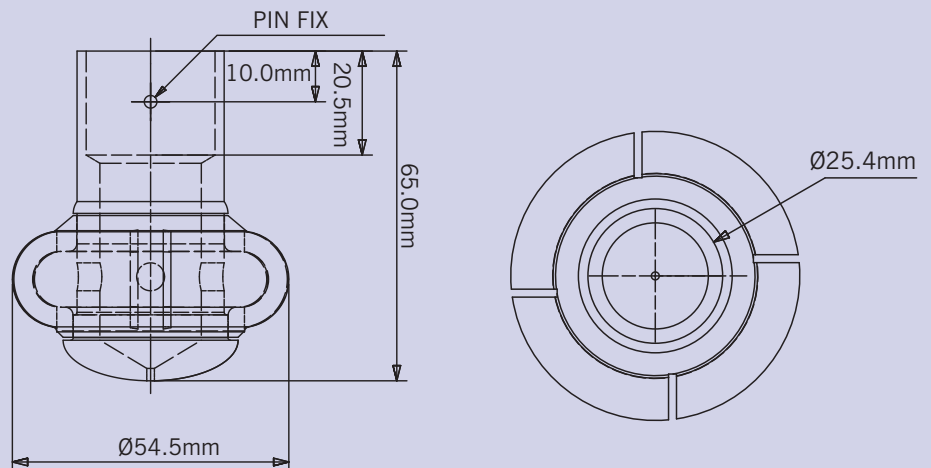

For optimal efficiency use a pre-filter or strainer to prevent particulate clogging.

BRECONCHERRY SELLERSCLEAN

WWW.TECPRO.COM.AU