



## THE PERFECT LOW COST SPRAYBALL REPLACEMENT

- Ultra Hygienic Design
- No Ball Bearings
- Low Maintenance
- Fast Aggressive Wash
- FDA, USDA, 3A Compliant
- Reduced Contamination
- Low Lifetime Cost
- Reduced Down Time

### Versatile & Unique

The Sani-Disc is designed for use in ultra hygienic applications where product purity and elimination of contamination problems are essential. The simple easily disassembled construction meets all the needs of regulatory bodies, and means the unit is also very cost effective. The unique disc design gives instant and complete uniform coverage of all internal surfaces providing a quick aggressive wash.

### Applications

The Sani-Disc is ideal for replacing fixed or rotating spray balls or other rotating units where a quick aggressive wash is required. The high energy, high impact droplets provide very effective impingement up to two and a half metres depending on the size of the unit chosen, which means that a single unit can clean vessels up to five metres in diameter. Simple in design, effective in performance, they meet all the essential FDA, USDA and 3A material and design requirements. This makes the units highly suitable for the pharmaceutical, biotech, food, beverage and other hygiene conscious industries. ATEX exempt units are also available.

### Operation

Wash fluid drives a simple rotating disc. The disc spins providing an instant and total coverage of all the internal surfaces of the vessel. All the wash fluid exits the unit over the disc creating powerful high energy droplets. The wash is fast and aggressive, delivering optimum performance in a short timescale. The units are also ideal for burst rinsing.

# SANI-DISC

## BRECONCHERRY SELLERSCLEAN

International specialists in the design and manufacture of tank cleaning equipment

Australia & New Zealand Distributor:



**TECHNICAL PROJECTS**  
DIN. OF MATHI PRODUCTS PTY. LTD A.B.N. 83 090 115 478

4/44 Carrington Road  
Castle Hill NSW 2154  
Australia

Tel: +61 (0)2 9634 3370  
Fax: +61 (0)2 9634 6418  
Email: sales@tecpro.com.au  
Web: www.tecpro.com.au



We reserve the right to change specification without notice. Whilst we endeavour to provide accurate up to date information, all information is provided as a guide only.

"Breconcherry", "Sani-disc" are internationally registered trade marks of Breconcherry Limited. Copyright © Breconcherry Limited 1999

## Maintenance & Inspection

The low wear design requires minimal maintenance. Any spare parts, technical assistance or repair facilities required can be obtained through the global Breconcherry distributor network. As with all mechanical devices, it is recommended that the unit be regularly inspected for correct operation.

## Minimum Manhole/Flange Size

The minimum manhole/flange opening size required for unit insertion for the Sani-Disc 100 unit is 70mm, and for the Sani-Disc 150 unit it is 85mm.

## Technical Data

<b>Materials of Construction:</b>	Stainless Steel 316/316L, PTFE, CF-PTFE, Hastelloy
<b>Max. Operating Temperature:</b>	95° Centigrade
<b>Max. Ambient Temperature:</b>	140° Centigrade
<b>Standard Connections:</b>	1 Pin Fix
<b>Nozzle Characteristics:</b>	360° Spray Pattern

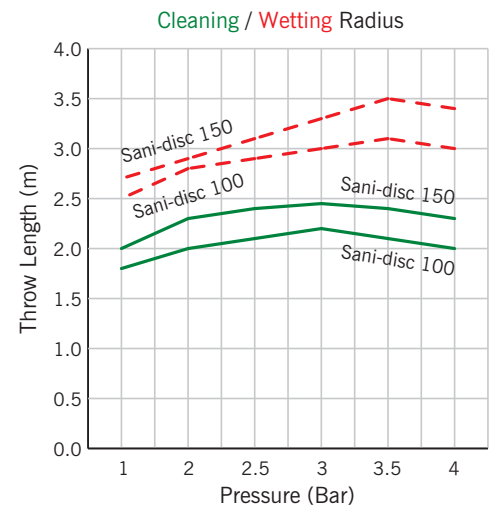
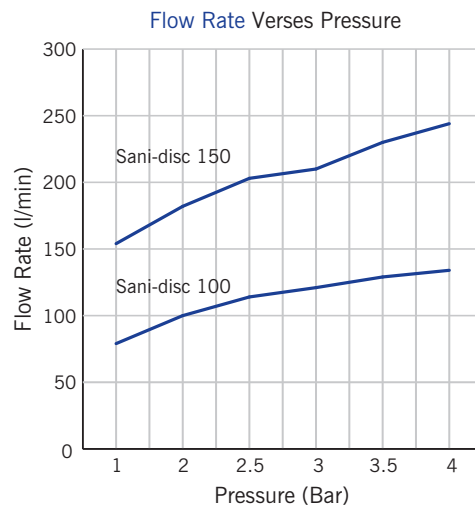

## General Arrangement Drawings

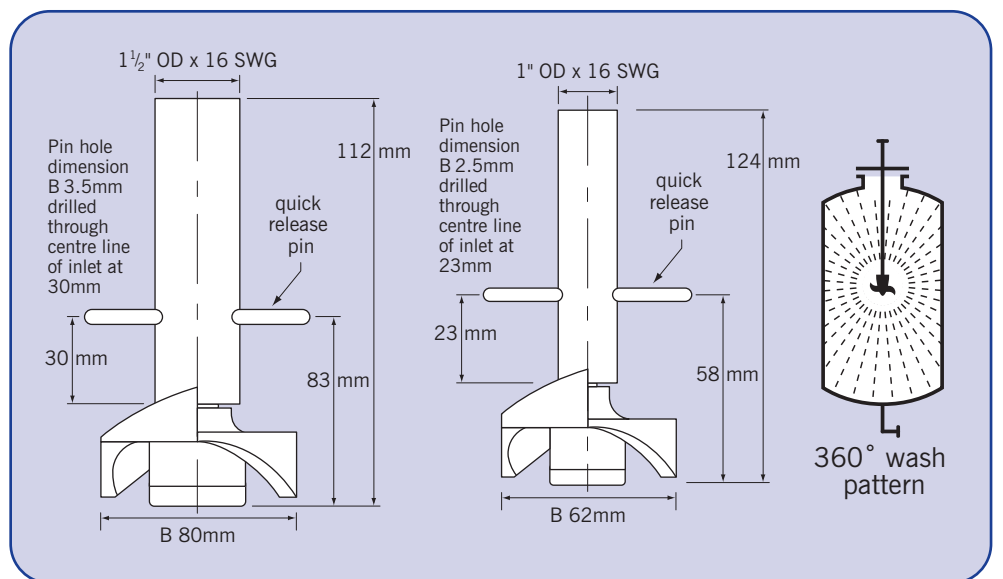

For optimal efficiency use a pre-filter or strainer to prevent particulate clogging.

## BRECONCHERRY SELLERSCLEAN

WWW.TECPRO.COM.AU