

# STAINLESS STEEL STEAM & COLD WATER MIXING UNIT - DURAMIX 8000GM-S SERIES

SuperKlean is proud to introduce the most innovative steam and cold water mixing unit specifically designed to provide safe and efficient means of clean up by producing hot water instantly with little or no maintenance. The DURAMIX 8000 unit operates under a wide range of steam and water pressures without changing internal components. In fact, it is one of the only steam and cold water mixing units in the industry with the ability to operate with as little as 30 PSI of water pressure. Its dual output design provides the user with the ability to supply two individual terminals with their own hot water supply. Its unique internal design does not allow live steam to penetrate, thus making this unit the safest in the market.



Part #:	Description
<b>8000GM-S</b>	300 series stainless steel, steam and cold water wall mounted mixer-hose station
<b>8000GM-S-T</b>	300 series stainless steel, steam and cold water wall mounted mixer-hose station with adjustable angle temperature gauge

### Principal Parts & Materials

Inlet / Outlet Diameter: 3/4" NPT  
 Mixer Body: 300 Series Stainless Steel  
 Check Valves: 300 Series Stainless Steel  
 Hose Rack: 300 Series Stainless Steel  
 Temperature Gauge: (optional) Stainless Steel

### Recommended Operative Conditions

Working Steam Pressure (Saturated Only): 30-150 PSI  
 Working Water Pressure: 30-150 PSI  
 Maximum Temperature: 200°F (93°C)  
 Maximum Pressure: 150 PSI  
 Weight: 20 Lbs.

If steam to water ratio is more than 2:1, please refer to "Operative Instructions" section 4.

## DURAMIX 8000 TECHNICAL DRAWINGS

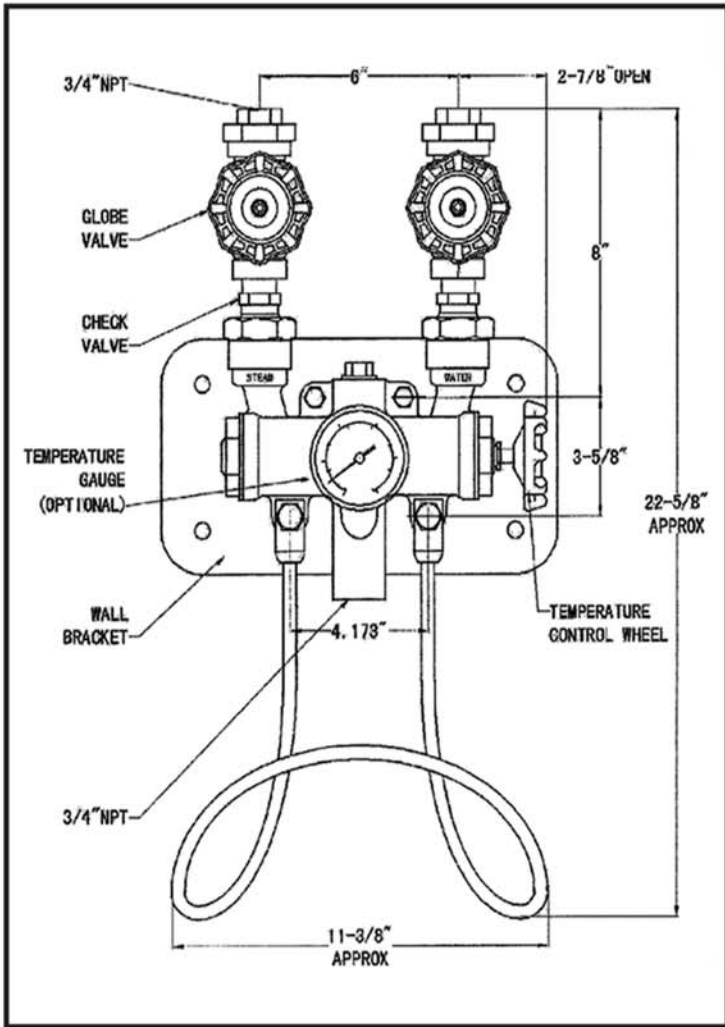

**FRONT VIEW**

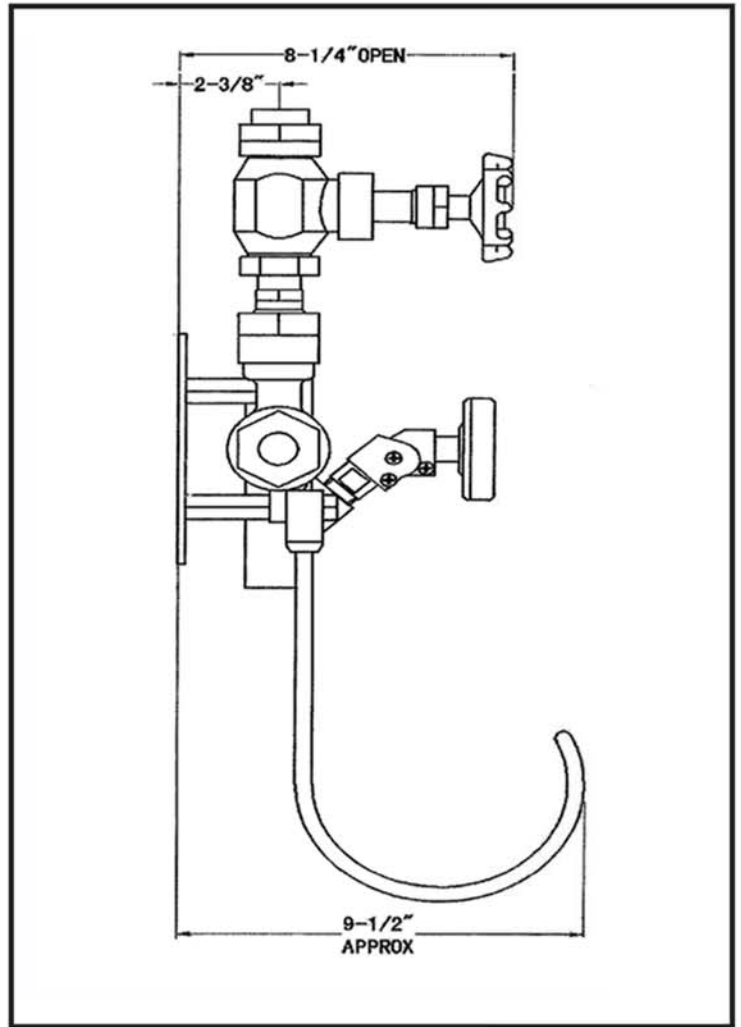

**SIDE VIEW**

## DURAMIX 8000 GPM RATINGS

### Temperature Rise vs. GPM

(for reference only)

INPUT		OUTPUT	
Steam*	Water	Temperature Rise	GPM
100 psig	60 psig	55° F	14.0
100 psig	60 psig	100° F	9.0
100 psig	60 psig	135° F	7.8
* Saturated Steam Only			