

## Chemical Reels

ReCoila® Gen III WP series offers a lightweight corrosion proof solution for the dispensing of herbicides and pesticides. Ideally suited to spot spraying from quad bikes and small vehicles.

Model	Hose ID	Hose Length	Max PSI	Inlet Fitting	Outlet Fitting	Temp Range	Weight
WP1015	10mm	15m	240	3/8" BSPF	3/8" BSPM	-5/+60°C	12Kg
WP1020	10mm	20m	240	3/8" BSPF	3/8" BSPM	-5/+60°C	12Kg
WP1215	12mm	15m	240	1/2" BSPF	1/2" BSPM	-5/+60°C	12Kg
WP1218	12mm	18m	240	1/2" BSPF	1/2" BSPM	-5/+60°C	12Kg

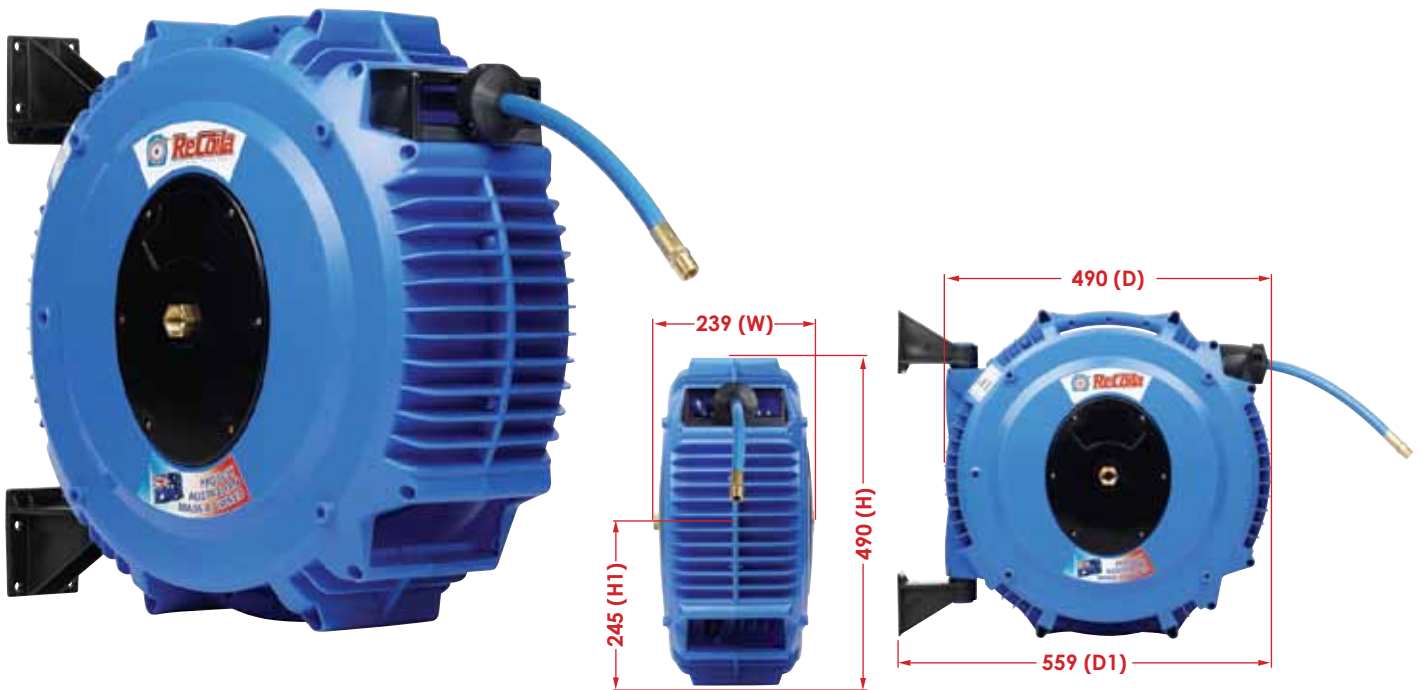

Note:  
NPT, JIC, JIS, Metric threads are available on request. Maximum working pressure of the hose is based on 240 psi @ 30°C.



## Gen III Features & Benefits

ReCoila® Gen III composite construction reels lead the world in design, functionality, reliability and innovative features.

ReCoila® was one of the first in the world to develop and manufacture composite spring rewind reels and today we continue to be world leaders.

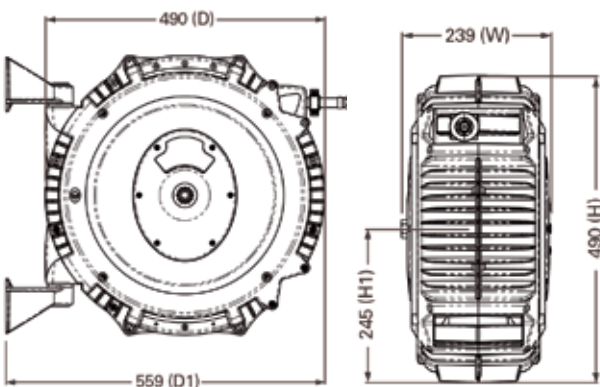

- Up to a 5 year warranty
- Highest quality 'finished edge' spring steel strip
- Full flow swivels and fluid paths
- Positive crimp hose fittings
- All position positive latching system
- Tough, impact, corrosion resistant and UV stabilized polypropylene with anti static and flame retardants
- Unique ratchet tensioning system
- Heavy Duty wall mounting swivel system
- Replaceable protective mouth guard
- Large side covers for easy access in servicing and maintenance routines
- Food grade approved materials
- Unique service locking pin port for added safety
- Two part fully adjustable bumper
- Detailed operation and service manual
- Easy mount drill hole pattern supplied

